

GIO56\_REV1.5

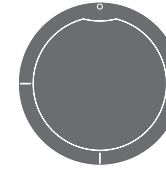

DESIGN  
NATALINO MALASORTI



GIO56/GIOTTO  
AISI 316L STAINLESS STEEL

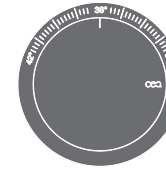

Gruppo doccia con miscelatore  
termostatico e deviatore 2/3 vie  
*Thermostatic shower mixer set  
with 2/3 way diverter*



Alta portata (≥ 25 l/min)  
*High water flow (≥ 25 l/min / ≥ 6.6 gpm)*

Possibilità di installazione a 90°  
*Installation possibility at 90°*

Prodotto che necessita di parte incasso  
*Product that needs built-in part*

**FIX** Staffa ausiliaria per cartongesso / fibrogesso  
*Auxiliary bracket for plasterboard / fiber-board structures*

#### MANUTENZIONE / MAINTENANCE

NON UTILIZZARE DO NOT USE		acido clorico e muriatico <i>chloric and muriatic acid</i>
		acido fluoridrico <i>hydrofluoric acid</i>
		ipoclorito di sodio <i>chlorine bleach</i>
UTILIZZARE TO USE		detergente a pH neutro <i>neutral pH detergent</i>

Questi disegni sono proprietà di CEADDESIGN SRL s.u. pertanto non potranno essere utilizzati e/o comunicati a terzi, anche in forma parziale, senza preventiva autorizzazione. CEADDESIGN SRL s.u. si riserva il diritto di apportare modifiche ai disegni al fine di migliorare il prodotto.

CEADDESIGN SRL s.u. has the property rights on these drawings, therefore they cannot be used and/or transferred to third party, even in partial form, without any prior authorization. Furthermore CEADDESIGN SRL s.u. reserves the right to apply any change to these drawings in order to upgrade the product.

**CEA**

ceadesign.it

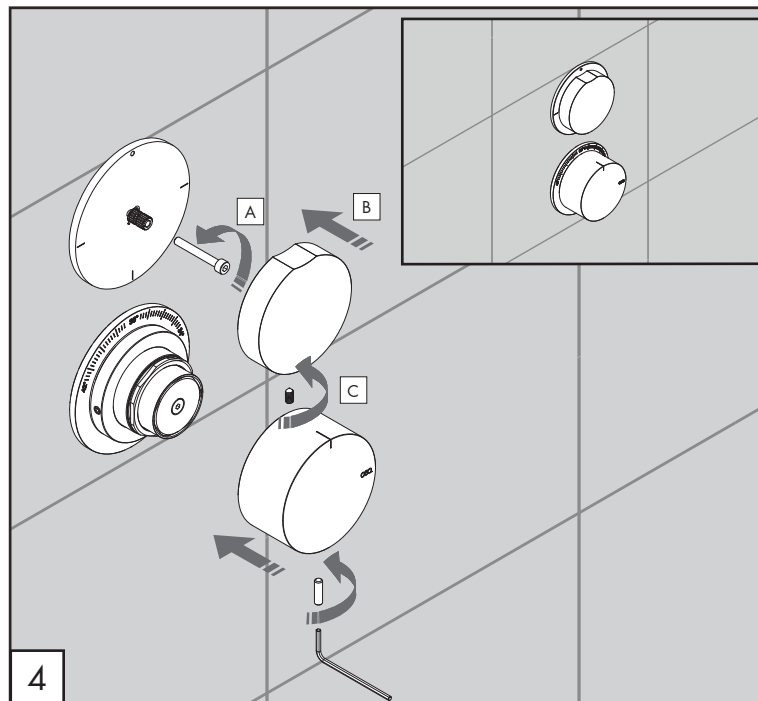
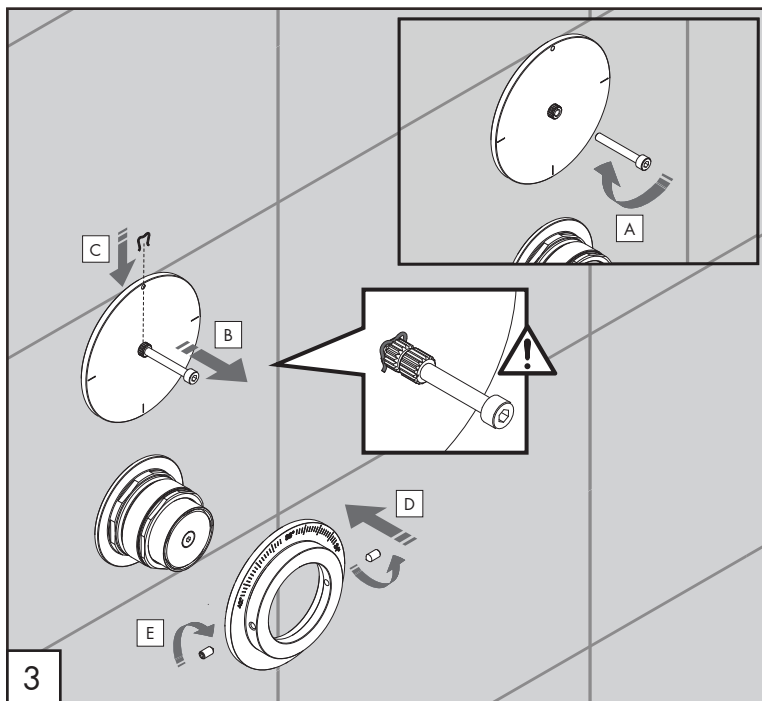
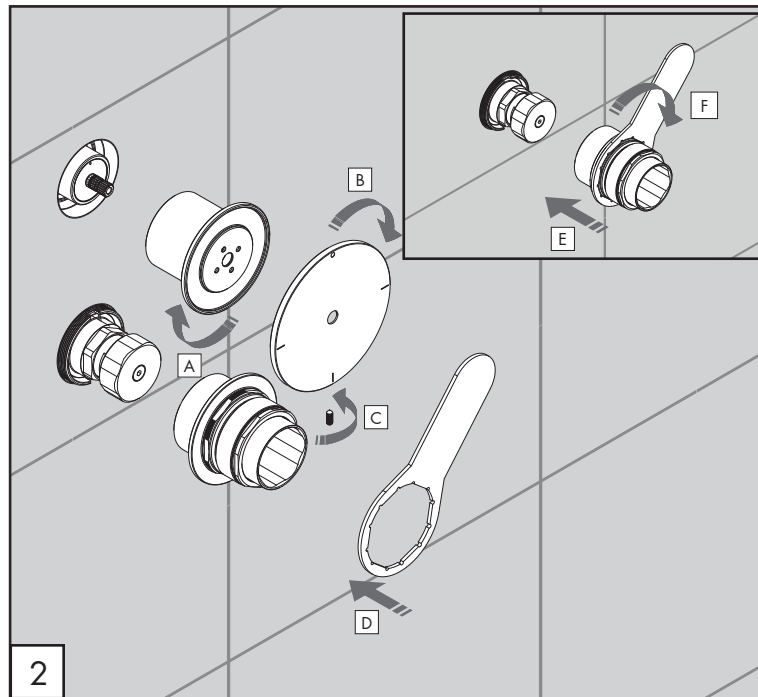
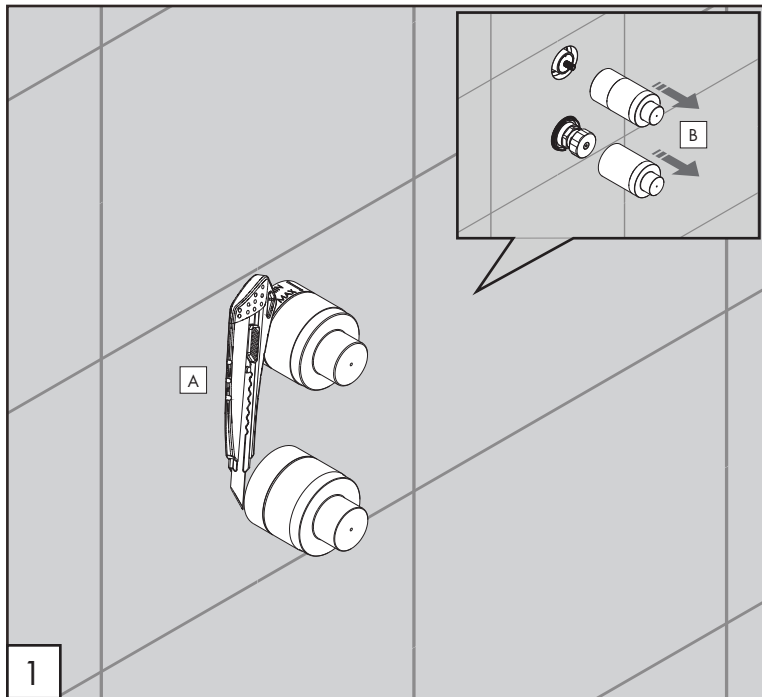

## AVVERTENZE TECNICHE

Risciacquare bene le tubazioni prima del montaggio ed evitare sbalzi di pressione fra i raccordi d'acqua fredda e d'acqua calda. In caso di pressioni statiche superiori a 5 bar si raccomanda l'installazione di un riduttore di pressione per evitare danni alla cartuccia.

## TECHNICAL WARNINGS

The pipes have to be rinsed thoroughly before installation. Avoid pressure differences between hot and cold water supply. Use of a pressure reducer when static pressure is higher than 5 bar to avoid damage of the cartridge.

## TECHNISCHE WARNUNG

Spülen Sie die Leitungen vor dem Einbau und verhindern Sie Wasserdruckwechsel zwischen kalt und warm Wasserverbindungen. Wenn Wasserdruck größer als 5 bar ist, bitte reduzieren Sie den Systemdruck, um Beschädigung der Kartusche zu verhindern.

## ADVERTENCIA TÉCNICA

Los tubos tienen que ser enjuagados a fondo antes de la instalación. Evitar grandes diferencias de presión entre las conexiones de agua caliente y fría. En caso de presión estática mayor de 5 bar, se recomienda el uso de un adaptador de presión para evitar daños en el cartucho.

## ADVERTISSEMENTS TECHNIQUES

Rincer les tuyaux avant l'installation. Eviter des grandes différences de pression entre l'eau froide et chaude. En cas de pressions statique de plus de 5 bar, nous vous recommandons d'installer un réducteur de pression pour éviter des dommages à la cartouche.

## PORTATE / FLOW RATE

BAR	uscita 1 / outlet 1		uscita 2 / outlet 2	
	l/min	gpm	l/min	gpm
1	17,3	4.6	15,1	4.0
2	20,4	5.4	21,8	5.8
3*	25,3	6.7	27,0	7.1
4	29,2	7.7	31,3	8.3
5	32,7	8.6	34,9	9.2

BAR	uscita 3 / outlet 3	
	l/min	gpm
1	11,6	3.1
2	16,6	4.4
3*	20,3	5.4
4	23,1	6.1
5	25,7	6.8

\* Pressione consigliata  
Recommended pressure

max. 65 °C  
max. 149 °F

## RICAMBI / SPARE PARTS

RICB053	Carter / Carter
RICM111	Maniglia / Handle
RICM118	Maniglia / Handle
RICM145	Maniglia / Handle
RICR094	Rosetta / Rosette
RICR114	Rosetta / Rosette

 Conservare gli strumenti inclusi nel prodotto e utilizzati per l'installazione perchè riutilizzabili per i ricambi.

Please, keep the tools included in the item pack and employed for its installation, to re-used them for the spare parts.

Die im Produkt enthaltenen Werkzeuge aufbewahren, da sie für die Ersatzteile wiederverwendet werden können.

No tirar las herramientas incluidas en el producto y usadas durante la instalación puesto que se pueden reutilizar para los recambios.

Veuillez conserver les outils inclus dans la boîte du produit et employés pour son installation, parce que réutilisables pour les pièces de rechange.

## LEGENDA / LEGEND

### ICONE / ICONS

 Utensile incluso nel ricambio  
Tool included in spare part

### FINITURE / FINISHES

\*S finitura satinata / satin finish  
L finitura lucidata / polished finish

### FINITURE SPECIALI / SPECIAL FINISHES

KD black diamond  
Z bronzo / bronze  
P rame / copper  
X light gold

### ESSENZE LEGNO / WOOD ESSENCES

\*WE wengé / wenge  
N noce canaletto / canaletto walnut  
T teak birmano / burma teak  
O rovere / oak

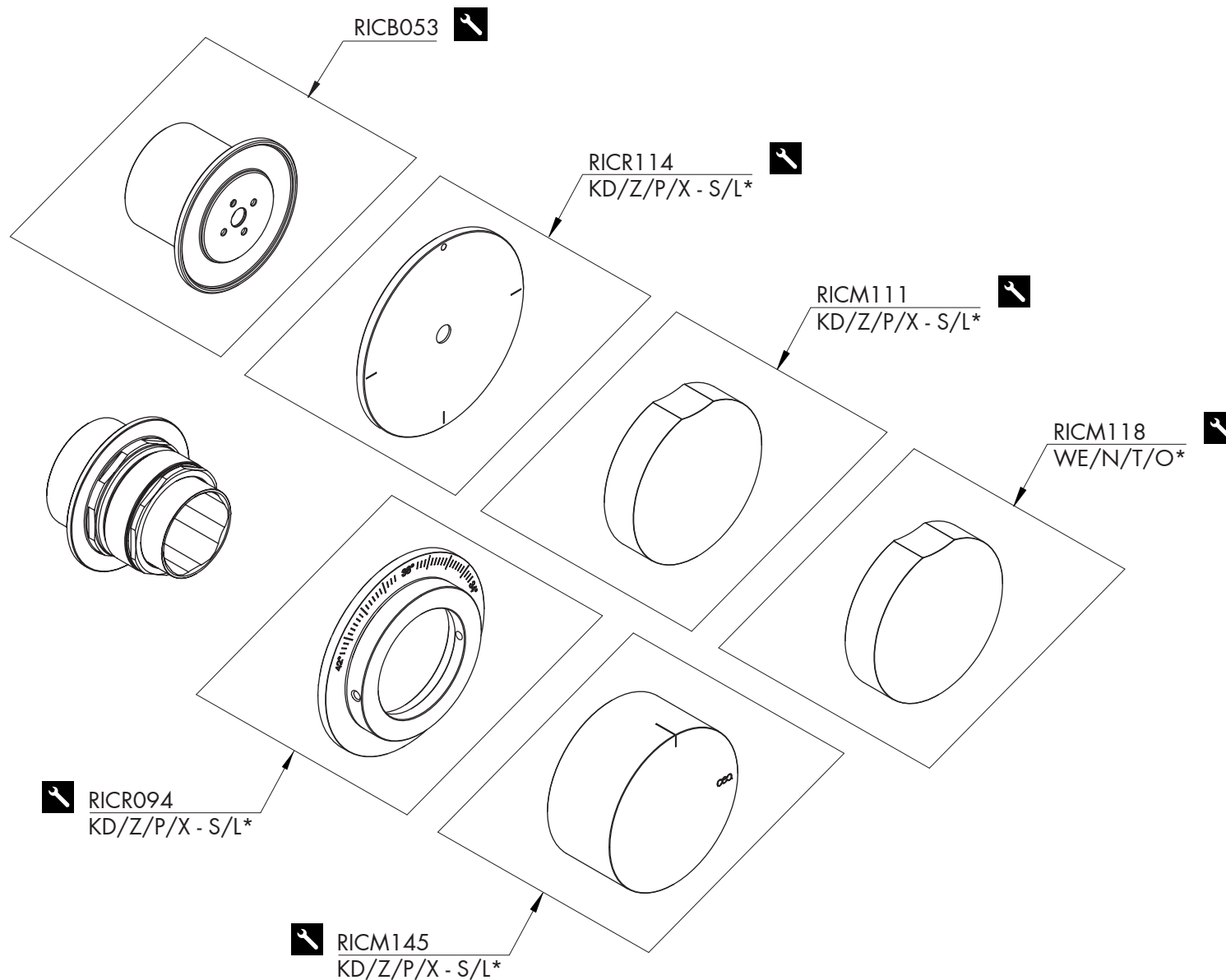

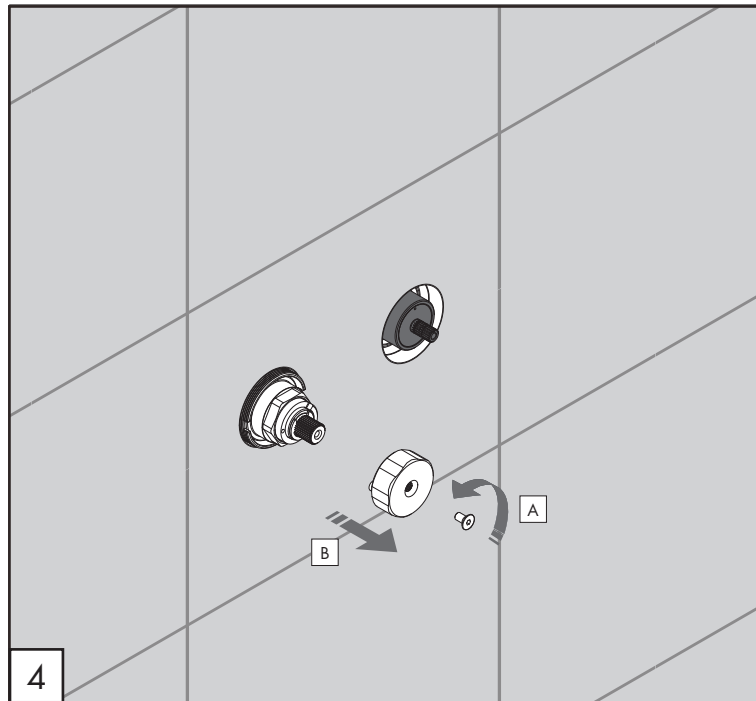
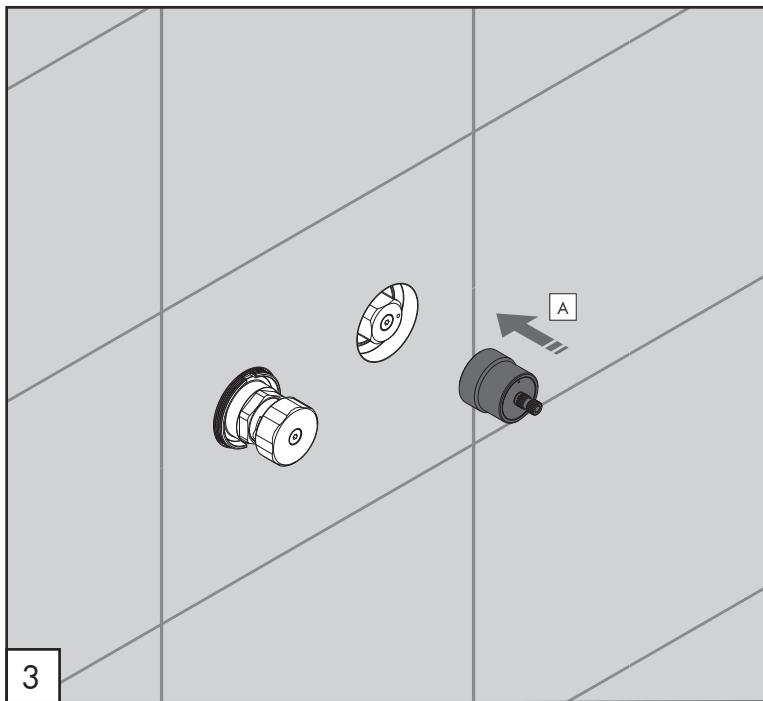
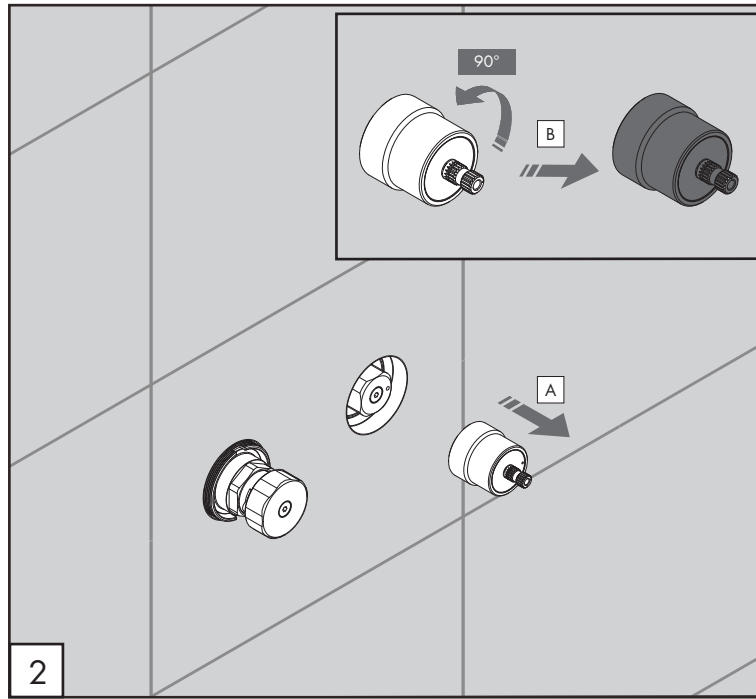
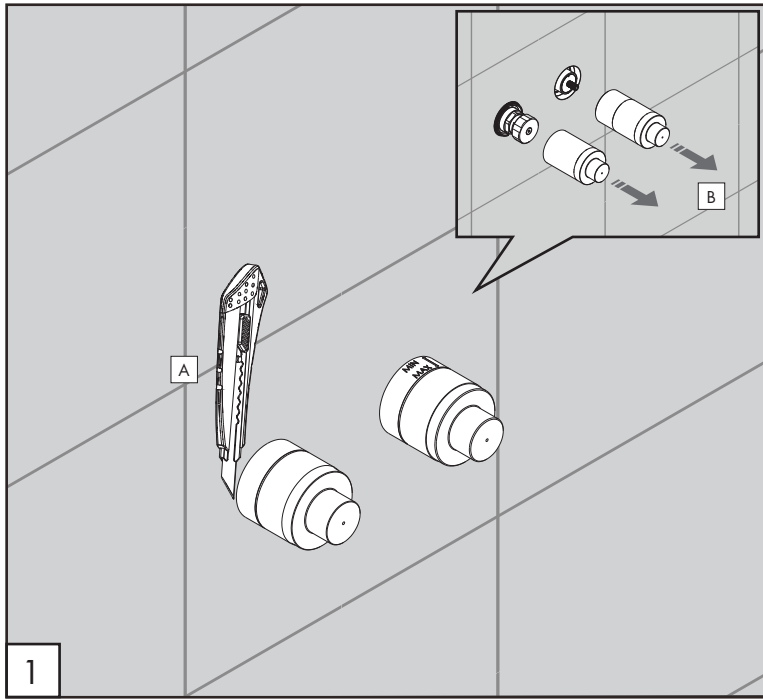

KEY01 \_REV10



CEA DESIGN STUDIO

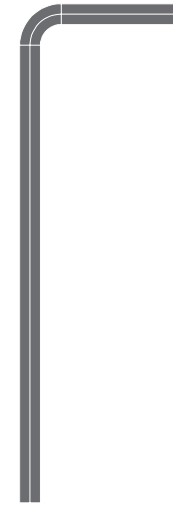

KEY01 /GIOTTO  
AISI 304 STAINLESS STEEL

Chiave per la rotazione  
del prodotto a 90° - 180°

Key for product rotation  
at 90° - 180°

CEA

ceadesign.it

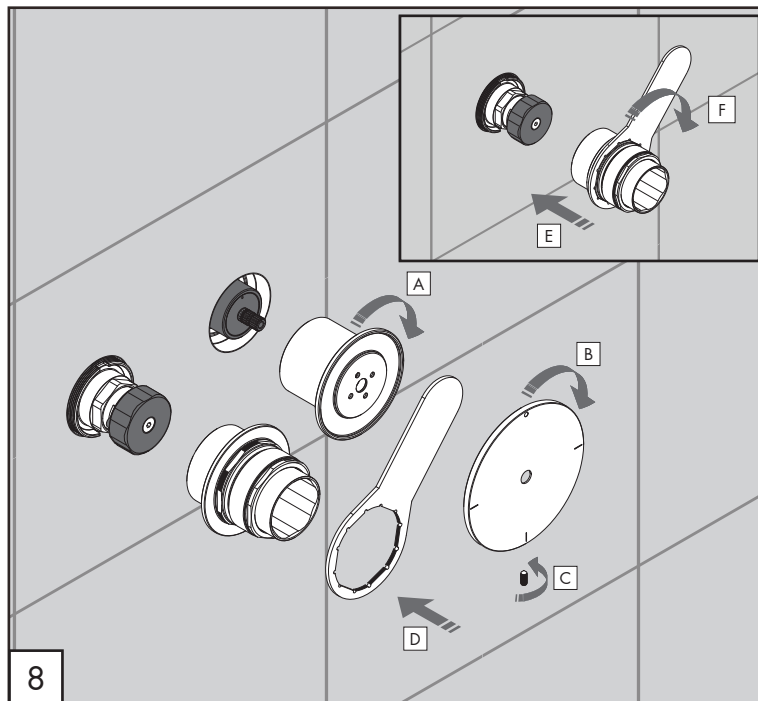
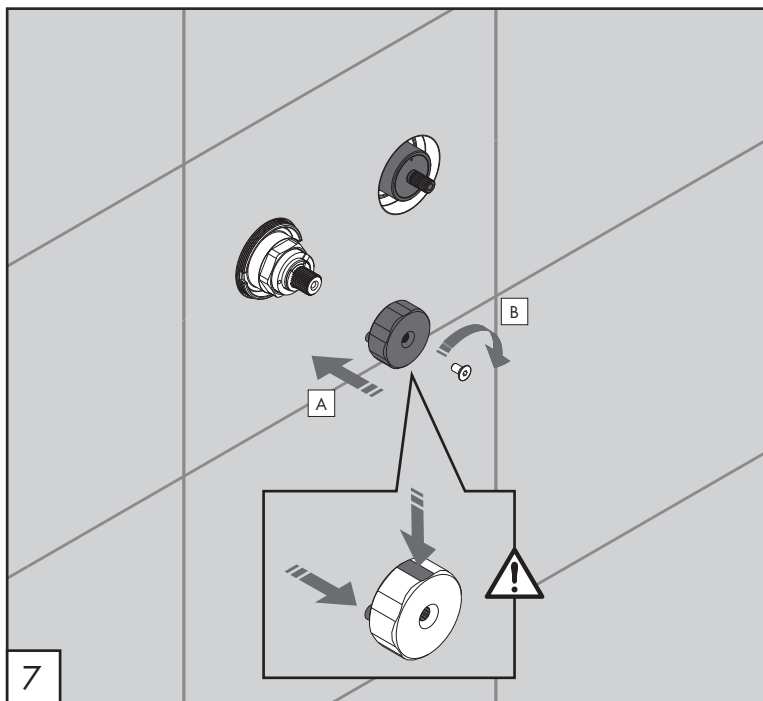
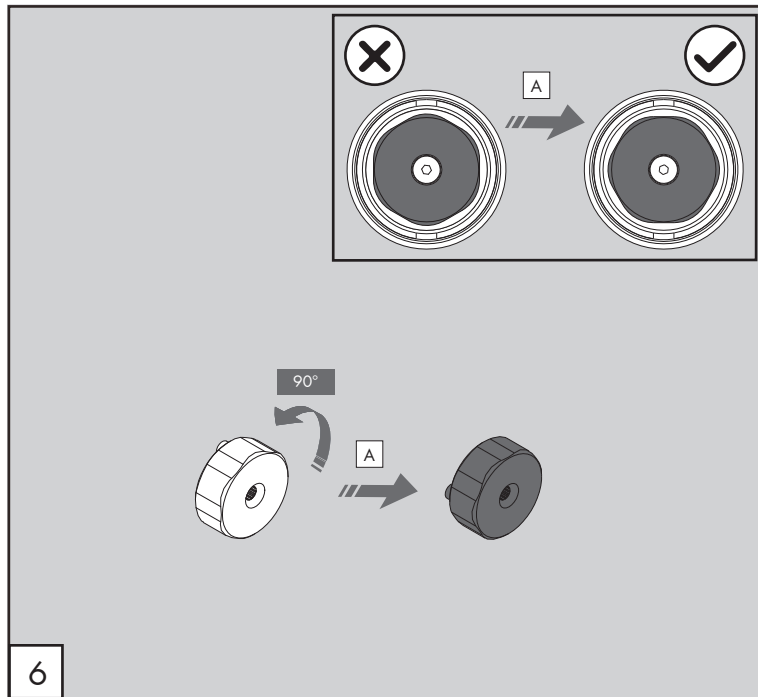
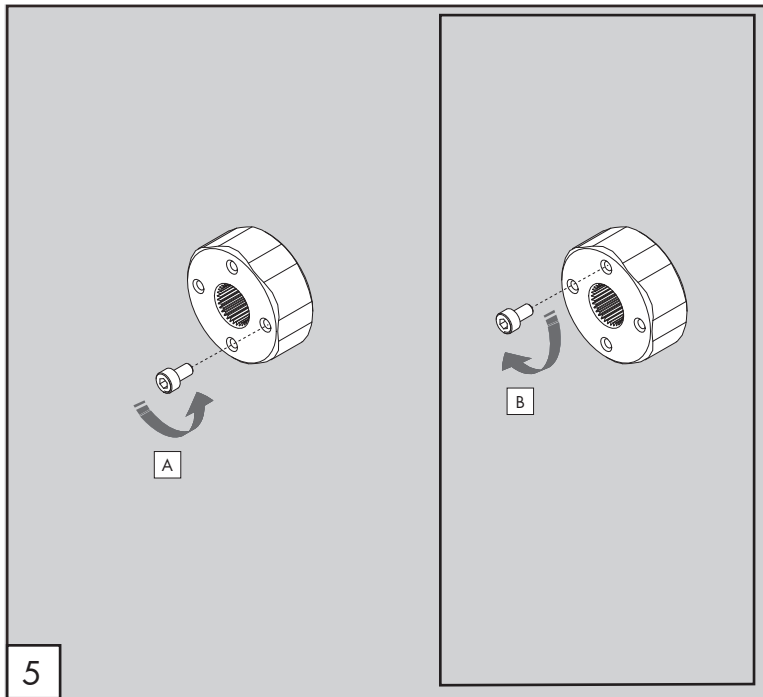

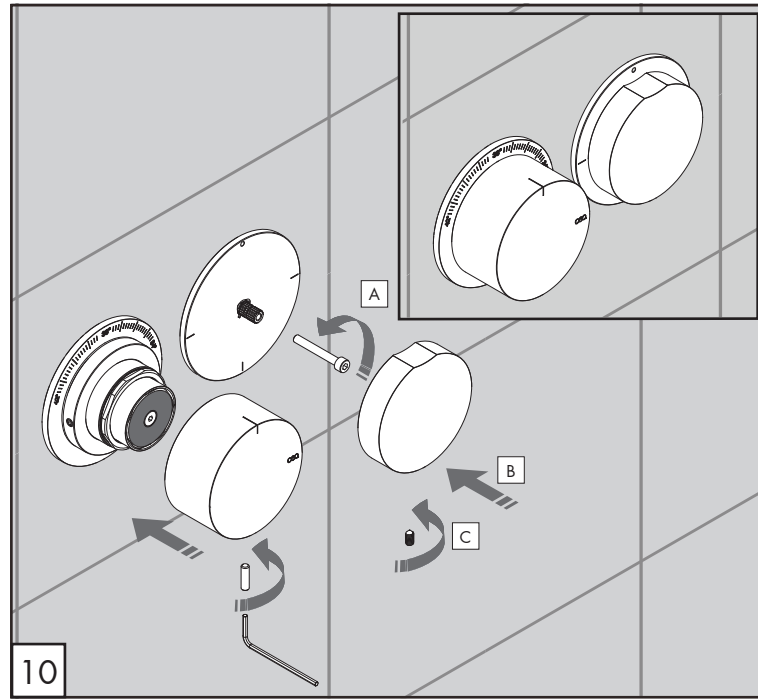
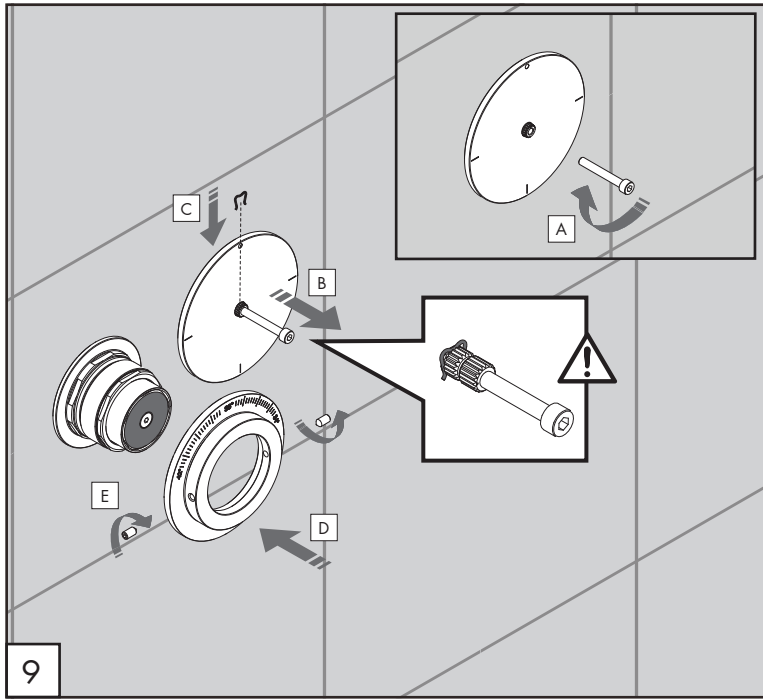

KEY01 \_REV10

