

PIETBOON  
by COCOON

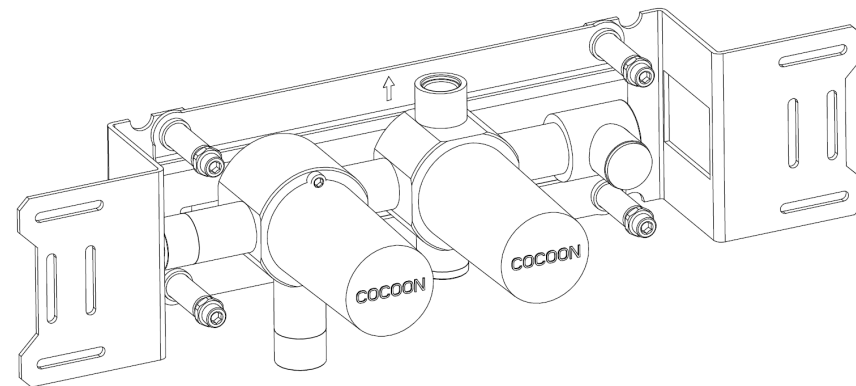

BOX03-3W-316-2021-USA



**Please ensure you comply with the following instructions to optimise performance of the shower mixer:**

- All pipework must be thoroughly flushed prior to installation
- For USA installation, please fix the USA NPT adapters on top of the pre-installed water connections
- Always first test the system with water pressure before closing the walls
- Optimal water pressure 3 BAR / temperature should not exceed 65°C/149°F
- Manufacturer has pre-set the thermostatic valve at 38° C/100°F (see position on the drawing). Maximum temperature at 3BAR 49°C/120°F
- Please read all installation instructions carefully

**Failure to comply with manufacturers recommendations will void warranty**

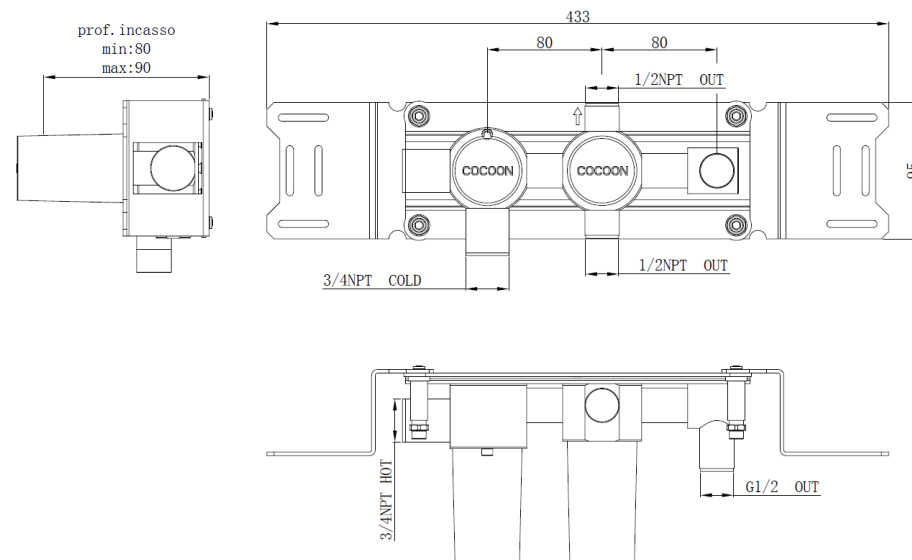

1

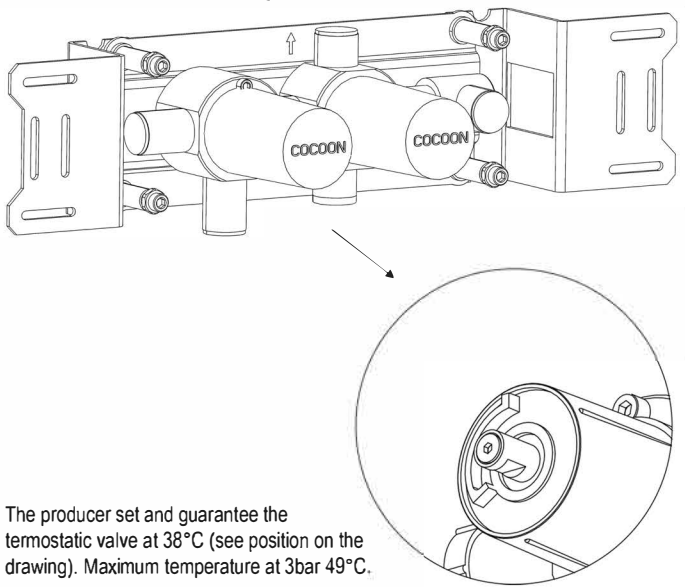
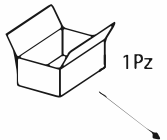

The producer set and guarantee the thermostatic valve at 38°C (see position on the drawing). Maximum temperature at 3bar 49°C.

2

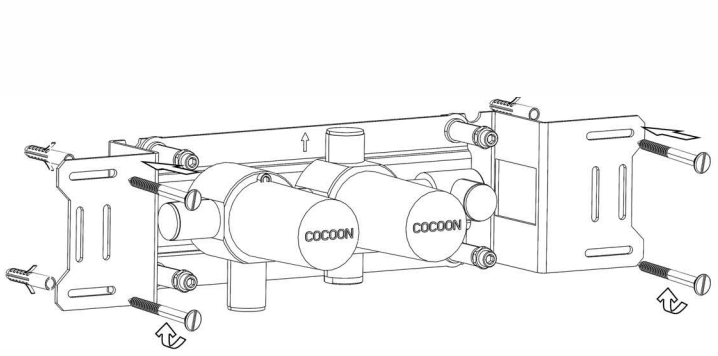

3

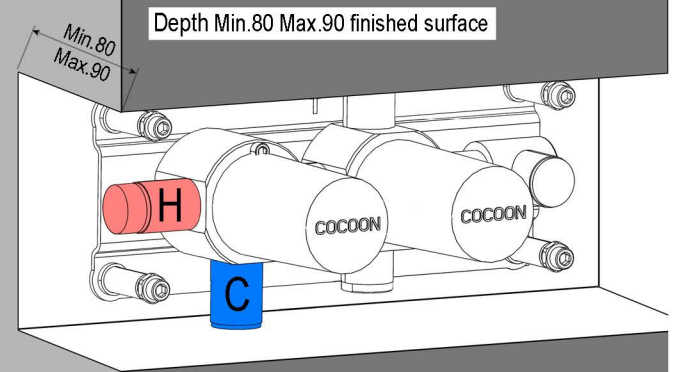

Depth Min.80 Max.90 finished surface



Connect and test the plant (3bar)

4

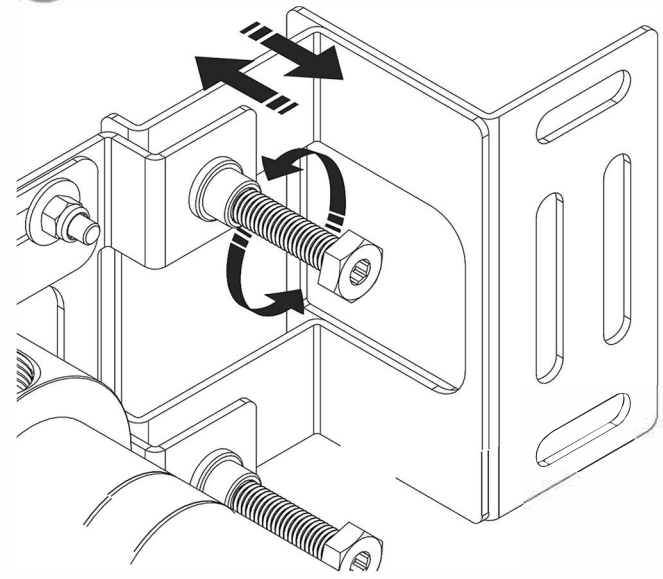

5

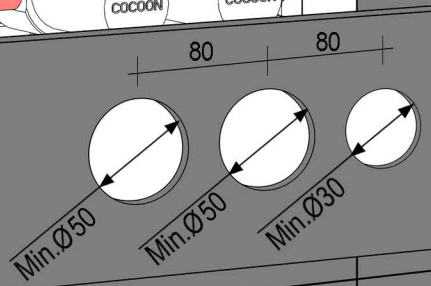
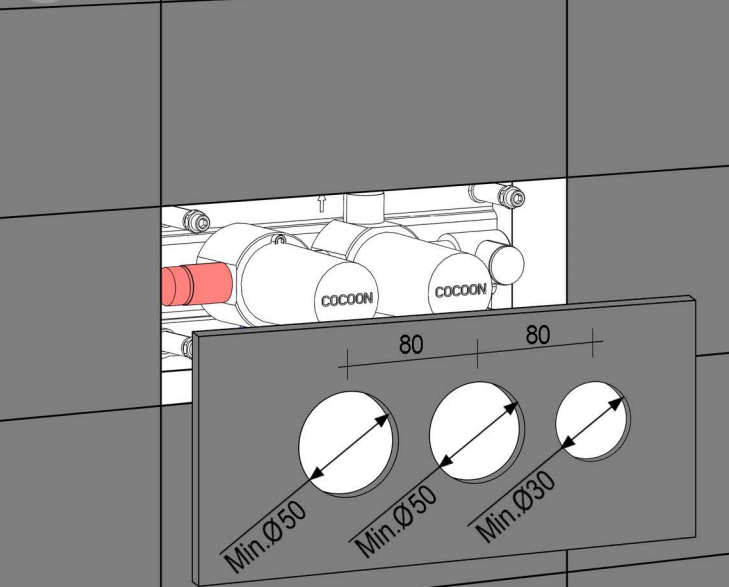

6

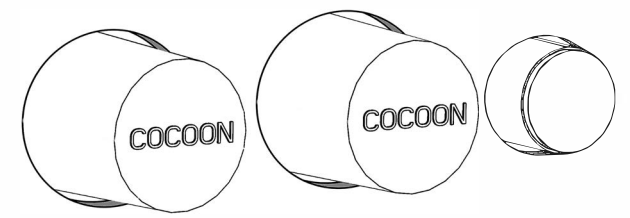

BOX 03-3W-316-2021-USA